

Suction and pressure vehicle with waterrecyclingsystem

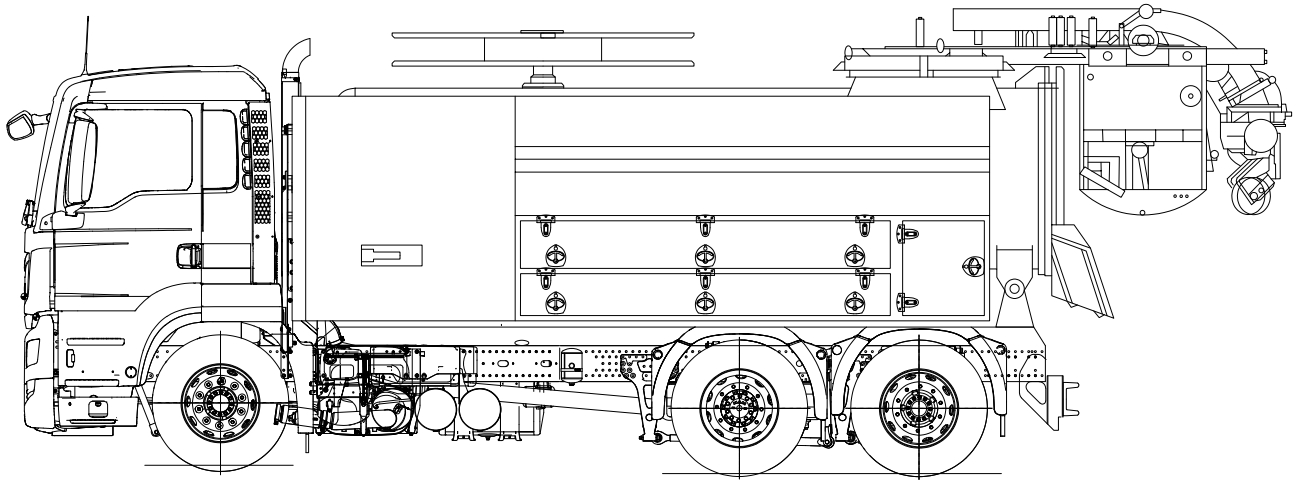

Chassis

Manufacturer MAN
 Type TGS 28.470
 Axle Configuration 6x2
 HP 470

Weights

GWV kg 28.000
 Weight technical kg 26.000
 Gearbox Automatic

Superstructure

Manufacturer Wiedemann enviro tec
 Type Super 2000 8,0 / 5,0 / 1,0
 Tank material Stainless Steel 1.4301
 Emptying Tipper

Total Volume l 14.000
 Water Chamber l 5.000 + 1.000
 Mud Chamber l 8.000

Sizes/Weight

L x W x H mm 9.900 x 2.550 x 3.700
 Wheelbase mm 3.900
 Payload kg 6.940

High-Pressure System

Manufacturer URACA
 Type P3-45/65
 Performance appr. 413l/min. @ 175 bar
 High-Pressure Hose 1 180m DN32
 80m DN13

High-Pressure System II

Manufacturer Speck
 Type NP 25/50-150
 Performance appr. 50l/min. @ 150 bar
 Suction Hose 1 15m DN10

Vacuum System

Manufacturer Wiedemann Reichhardt
 Type KW 4000
 Performance appr. 4.000m³/h
 Suction Hose 1 25m DN125

Notes

.....

